



F3 RE 15/20 CMC (COMPACT) . RETRACTABLE TAIL-LIFT CHROMED GUIDES - 5 CYLINDERS

LOAD CAPACITY

- 1500 KG
- 2000 KG



TECHNICAL SPECIFICATIONS

Cylinders:	2 lift cylinders + 2 tilt cylinders + 1 automatic tilt cylinder
Sliding system:	Chromed Guides with hydraulic motor + rack and pinion drive
Tilt cylinders:	Single acting
Automatic tilt at ground level:	Yes, Hydraulic
Platform material:	Aluminium
Standard platform depths Alu:	1 fold 1483 - 1683 - 1783 mm (max 2033) 2 folds 1333 - 1633 - 1833 mm
Standard platform widths Alu:	2100 - 2250 - 2400 mm (Max 2500)
Lift arm lengths:	C - H - HS - HSS
Lift arm widths (W):	1230 mm
Standard control:	Unit Exterior control box with joystick, turn button

APPLICATIONS

The retractable tail-lift F3RE 15/20 CMC COMPACT is the ideal tail-lift for distribution vehicles due to its versatility, large platforms and ease of use.

The tail-lift is stowed away under the vehicle making it ideal for dock loading.

F3RE 15/20 CMC COMPACT is suggested and especially designed for rigid vehicles with very short overhang.

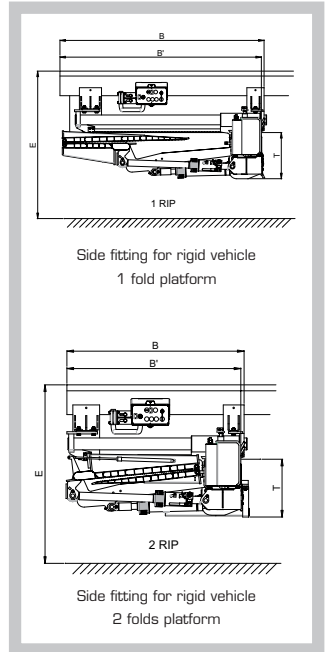
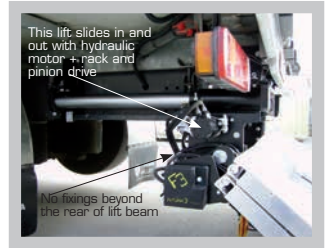

		RIGID VEHICLE						
Mod.		Load Capacity (centre of gravity at 600 mm)	E max	Platform Depth * (example)	B min	B' min	T	Weight ** (Kg)
1 FOLDS PLATFORM	F3RE15H	1500 kg	1285	1633 (750 + 883)	1690	1667	376	605
	F3RE15HS		1525	1633 (750 + 883)	1843	1821		630
	F3RE20H	2000 kg	1285	1633 (750 + 883)	1690	1667	376	605
	F3RE20HS		1525	1633 (750 + 883)	1843	1821		630
2 FOLDS PLATFORM	F3RE15H	1500 kg	1285	1283 (700 + 583)	1044	1022	376	545
	F3RE15HS		1525	1583 (850 + 733)	1197	1175		610
	F3RE20H	2000 kg	1285	1283 (700 + 583)	1044	1022	376	565
	F3RE20HS		1525	1583 (850 + 733)	1197	1175		630

* 1 folds platform: platforms depth from 1333 mm to 1983 mm. ** Approximate weight for tail-lift with platform width 2450 mm. Centre of gravity of the vehicle depending on the type of arm and the size of the installations on the vehicle [see assembly instructions]. The above mentioned weights are approximate and may vary according to production. Anteo reserves the right to change weights and technical specifications without prior notice. No indemnity for damages can be claimed from Anteo for changes in technical specifications and/or in weight.